

**PRESSURE SWITCHES
PRESSURE DIFFERENCE SWITCHES
VACUUM SWITCHES**
From 1.5 mbar to 600 bar



SM Pressure Switches

INSTALLATION AND OPERATING INSTRUCTIONS

CONSTRUCTION :

The pressure switch is housed in a machined aluminium enclosure which conforms to IP65 protection factor. The pressure capsule, at the bottom of the switch, comprises a pressure housing (either of aluminium, brass or SS316), a disc, nylon reinforced rubber diaphragm and a plunger. The electrical changeover is through a snapaction microswitch. For electrical wiring, a 4 core cable 450mm long has been provided.

PRINCIPLE OF OPERATION

The pressure in the pressure capsule is converted into force by means of a reinforced rubber diaphragm and a calibrated piston, which is balanced by a compression spring from above. When the force generated by the pressure in the pressure capsule exceeds / falls beyond the balancing spring force, an electrical element is actuated.

MOUNTING : (Fig. 1)

The SM model pressure switches can be mounted in any direction.

Following are the mounting instructions :

- 1) Pressure switches can be mounted directly in case the mounting is rigid. Connect the pressure tubing to the pressure port. The pressure port size is generally 1/4" BSP Female, unless specifically ordered otherwise. Other sizes can be obtained via adaptors.



Fig. 1

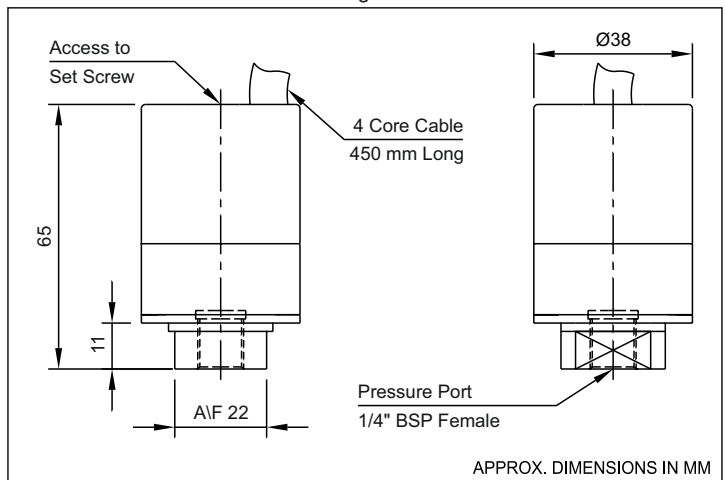
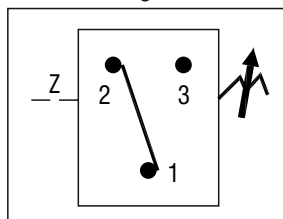

Fig. 2

ELECTRICAL CONNECTIONS : (Fig. 2)

Pressure switches will generally have only one SPDT micro switch.

Pressure switches with 2SPDT microswitches can also be provided. For 2SPDT microswitches, there will be a preset stage differential.



BULLETIN NO. : KA211025

Kaustubha Udyog (Orion Instruments)

S. No. 36/1/1, Sinhgad Road, Vadgaon Khurd, Pune 411 041 INDIA
Tel.: +91-(0) 20-24393877 / 24351592
Telefax : +91-(0) 20-24393577 / 25460486
Email : ku.pressure@gmail.com / info@orion-instruments.io

Certificate No.: FM72815



Website : www.orion-instruments.io

Fig. 3

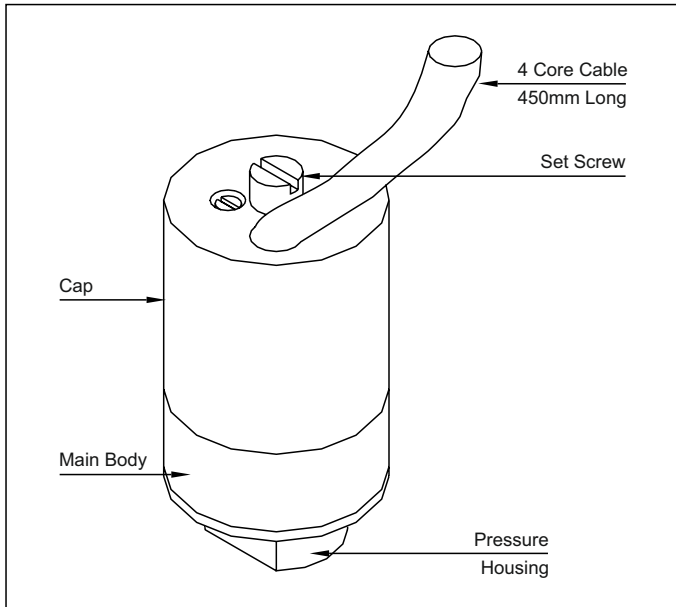
**WIRING :**

For electrical wiring, a 4 core cable 450mm long has been provided. The colour code is as per the details given below:

- terminal 1 (Common) : Red
- terminal 2 (Normally Closed) : Black
- terminal 3 (Normally Open) : Yellow
- terminal 4 (Earth) : Green

SET POINT ADJUSTMENT FOR SM MODELS

(Fig. 3)

- 1) Turn the setscrew to the extreme negative end.
- 2) Apply the desired cutin (lower) / cutout (higher) pressure to the pressure switch.
- 3) Increase the pressure setting by turning the setscrew till contacts changeover.
- 4) Some minor adjustment will be required to achieve the exact cutin (lower) / cutout (higher) point, which can be checked with the help of a proper pressure measurement device.

Tip.: The pressure switches are factory set at half the setpoint range (unless otherwise specified in a Purchase Order). Step 2 can be omitted if the desired set point is more than the factory setting.

TROUBLE SHOOTING TIPS

Generally no problems are observed if the pressure switch selection, wiring and the setpoint is proper. For a pressure switch selection procedure, please consult our sales office.

For properly selected pressure switches, if following symptoms are observed, the likely causes and remedies are as stated below.

SYMPTOM 1 : SWITCH DOES NOT OPERATE

- 1) Wiring may not be correct. Check electrical connections to the pressure switch, if they are as per the wiring diagram.
- 2) Pressure does not reach the pressure port.
 - a) Check if the entry to the pressure capsule is not blocked by frozen process or scales or impurities in the process.
 - i) If this is the case, try freeing the blocked path by a blunt tool in case of scales and impurities.
 - ii) For frozen process, it is advisable to use chemical seals.

DO NOT OPEN THE PRESSURE CAPSULE IN ANY EVENT.

If the cause is none of the above mentioned probabilities , proceed as per the following steps.

- b) Check the system pressure & set point of pressure switch.
 - i) For use of pressure switch for falling setpoints, system pressure has to be greater than the cutout point.
 - ii) For use of pressure switch for rising setpoints, system pressure may not be reaching / exceeding the cutout point.

Fig. 4

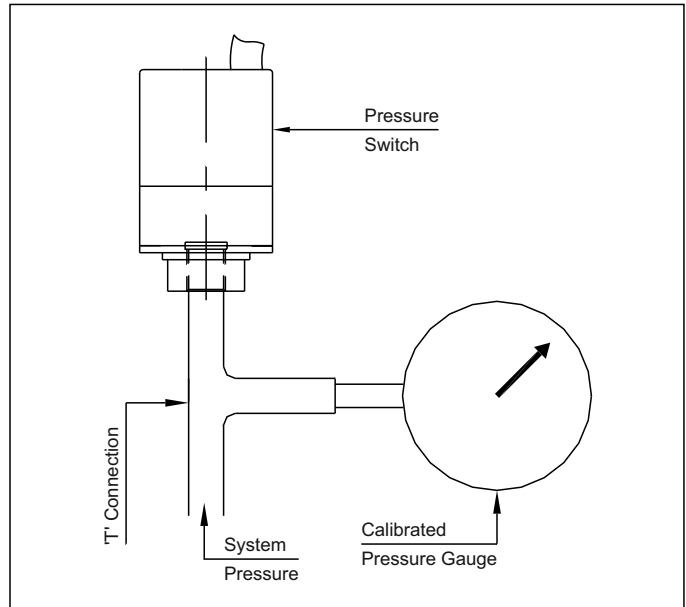

- c) Use 'T' connection & connect calibrated pressure gauge to the 'T' connection as shown in the figure.
- d) Adjust the setpoints such that the system pressure is greater than the cut-out point of the pressure switch.
- e) If the switch still does not operate, remove the pressure switch physically from the system. There should be continuity between terminals 1 & 2. If no continuity is observed, the pressure switch should be returned to the factory.

SYMPTOM2 : SHORT WIRING :

Isolate the switch electrically. Check the continuity between terminals and the screws fitted to the body. If no continuity is observed between any of the terminals and the screws fitted to the body, check the short connection elsewhere in the circuit. If continuity is observed, the wires of the pressure switch have internally touched the body, and the switch should be returned to the factory.

SYMPTOM3 : LEAKAGE :

In case leakage is observed, the pressure switch has to be returned to the factory without opening the pressure capsule. Check for the following likely causes and use a new switch taking proper precautions.

- a) System pressure is greater than working pressure : Use an overrange protector or a switch with appropriate maximum working pressure.
- b) Incompatible wetted parts : The working medium may not be compatible with wetted parts, which damages the sealing of the process from working parts. Use a chemical seal for the pressure switch or use proper compatible wetted parts.
- c) Excessive process temperature : Process temperature may exceed maximum allowable temperature, which in turn damages the diaphragms. Use an impulse tubing of proper length for cooling the process temperature. There may be a pressure drop depending on the length of the impulse tube used. Adjust the setpoint of the pressure switch accordingly.

SYMPTOM4 : CHATTERING :

- 1) Check the system pressure for surges. Chattering is observed where the system pressure is close to the cutin / cutout point and the surge pressure exceeds the on - off differential. Use a pressure switch with adjustable differential or use surge dampers in your system. ■